

D

C

B

A

D

C

B

A

| COPPER AIRCRAFT CABLE MIL-W-5036 | MS20659 DASH NO. | STUD SIZE | CATALOG NUMBER | DIMENSIONS | | | | | | | | R REF. | | INSTALLATION TOOLING | | | | | | |
|----------------------------------|------------------|--------------|----------------|---------------|---------|-----------|-------------|--------------------------------------|------|--------------|---|--|---|-------------------------------------|-----------|--------------|------|--|------------------------------------|-------------------------------------|
| | | | | C | N | Z MIN. | Y MAX. | L MAX. | T | B MIN. | R | REF. | NON - HYDRAULIC | | HYDRAULIC | | | | | |
| | | | | NON - RATCHET | RATCHET | PNEUMATIC | Y29B, Y29NC | Y35, Y35BH, Y39, Y39BH, Y750, Y750BH | | | | | | | | | | | | |
| AN 12 - 10 | 5 | 8 | YAV10T11 | .38 | .19 | .26 | .78 | .97 | .06 | .40 | .25 | Y10D, Y10-22 | Y10MRPA WITH J1022NC5 DIE MR8G98, MR89Q, Y8MRB1, MR20 | Y6NCB OR Y6NCP WITH J1022NC5 DIE | --- | --- | | | | |
| | 102 | 10 | YAV10 | .47 | .23 | .34 | .85 | 1.09 | .05 | .39 | .31 | | | | | | | | | |
| | 106 | 5/16 | YAV10T2 | .53 | .27 | | .86 | 1.13 | .04 | | | | | | | | | | | |
| | 128 | 3/8 | YAV10T4 | .56 | .28 | .37 | .89 | 1.17 | | | | | | | | | | | | |
| | | | | | | | | | | | | | | | | | | | | |
| AN-8 | 6 | YAV8CL15 | .41 | .20 | .28 | .94 | 1.15 | .07 | .38 | MY29-11 | MR4C, MR89Q, Y8MRB1, M8ND WITH N8CT DIE | Y6NCB OR Y6NCP WITH Y2CNC NEST AND J8CNC INDENTOR DIES | DV8LI NEST Y29PL INDENTOR (1) CRIMP | UV8L NEST Y34PL INDENTOR (1) CRIMP | | | | | | |
| | 140 | 8 | | | | | | | | | | | | | YAV8CL14 | | | | | |
| | 107 | 10 | | | | | | | | | | | | | YAV8CL | | | | | |
| | 141 | 1/4 | YAV8CL1 | .57 | .23 | .32 | .98 | 1.22 | .07 | | | | | | | | | | | |
| | 108 | 5/16 | YAV8CL2 | | | | | | | | | | | | | | | | | |
| | 129 | 3/8 | YAV8CL3 | .41 | .28 | .34 | 1.01 | 1.30 | .05 | | | | | | | | | | | |
| | 142 | 1/2 | YAV8CL4 | | | | | | | | | | | | | | | | | |
| | 143 | 3/8-10MM | YAV8CL32 | | | | | | | | | | | | | | | | | |
| | 144 | 5/8 | YAV8CL39 | .38 | .50 | .62 | 1.29 | 1.79 | .04 | | | | | | | | | | | |
| | 145 | 12 | YAV8CL86 | | | | | | | | | | | | | | | | | |
| | 146 | 1/4 | YAV8CL1B | | | | | | | | | | | | | | | | | |
| | 147 | 1/4 | YAV8CL1BOX500 | .38 | .23 | .32 | .99 | 1.22 | .07 | | | | | | | | | | | |
| | 148 | 10 | YAV8CLBOX500 | | | | | | | | | | | | | | | | | |
| | AN-6 | 130 | 10 | YAV6CL1 | .48 | .24 | .29 | 1.06 | 1.31 | | | | | | .07 | MY28 MY29-11 | MR4C | Y6NCB OR Y6NCP WITH Y2CNC NEST AND J6CNC INDENTOR DIES | DV6L NEST Y29PL INDENTOR (1) CRIMP | UV6L NEST Y34PLA INDENTOR (1) CRIMP |
| | | 131 | 10-5MM | YAV6CL25 | | | | | | | | | | | | | | | | |
| 109 | | 1/4 | YAV6CL | | | | | | | | | | | | | | | | | |
| 110 | | 5/16 | YAV6CL21 | .60 | .30 | .35 | 1.13 | 1.43 | .06 | | | | | | | | | | | |
| 111 | | 3/8 | YAV6CL2 | | | | | | | | | | | | | | | | | |
| 112 | | 3/8 | YAV6CL22 | .47 | .44 | .45 | 1.23 | 1.67 | .05 | | | | | | | | | | | |
| 113 | | 3/8-10MM | YAV6CL23 | | | | | | | | | | | | | | | | | |
| 114 | | 3/8-10MM | YAV6CL26 | | | | | | | | | | | | | | | | | |
| 115 | | 1/2 | YAV6CL10 | .38 | .38 | .49 | 1.26 | 1.64 | .06 | | | | | | | | | | | |
| 116 | | 10 | YAV6CL19BOX | | | | | | | | | | | | | | | | | |
| 117 | 1/4 | YAV6CLBOX500 | | | | | | | | | | | | | | | | | | |
| AN-4 | 144 | 10 | YAV4CL3 | .55 | .25 | .28 | 1.11 | 1.37 | .08 | MY28 MY29-11 | MR4C | --- | DV4L NEST Y29PL INDENTOR (1) CRIMP | UV4L NEST Y34PLA INDENTOR (1) CRIMP | | | | | | |
| | 145 | 10-5MM | YAV4CL21 | | | | | | | | | | | | | | | | | |
| | 111 | 1/4 | YAV4CL | | | | | | | | | | | | | | | | | |
| | 118 | 1/4 | YAV4CL30 | .28 | .35 | 1.18 | 1.46 | .08 | | | | | | | | | | | | |
| | 119 | 1/4 | YAV4CL31 | | | | | | | | | | | | | | | | | |
| | 120 | 5/16 | YAV4CL4 | .47 | .31 | .33 | 1.17 | 1.48 | .07 | | | | | | | | | | | |
| | 121 | 3/8 | YAV4CL2 | | | | | | | | | | | | | | | | | |
| 122 | 3/8 | YAV4CL17 | | | | | | | | | | | | | | | | | | |
| 123 | 3/8-10MM | YAV4CL22 | .69 | .38 | .47 | 1.30 | 1.68 | .06 | | | | | | | | | | | | |
| 124 | 1/2 | YAV4CL5 | | | | | | | | | | | | | | | | | | |

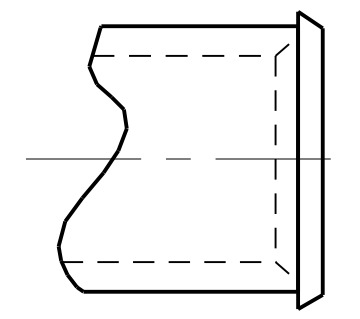
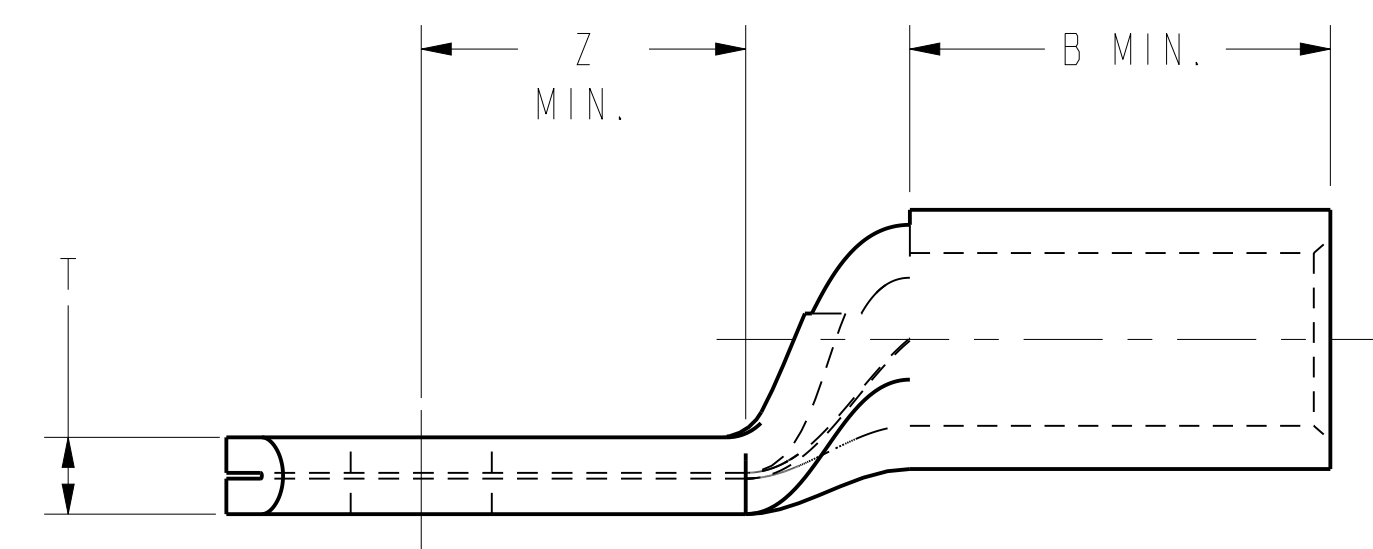
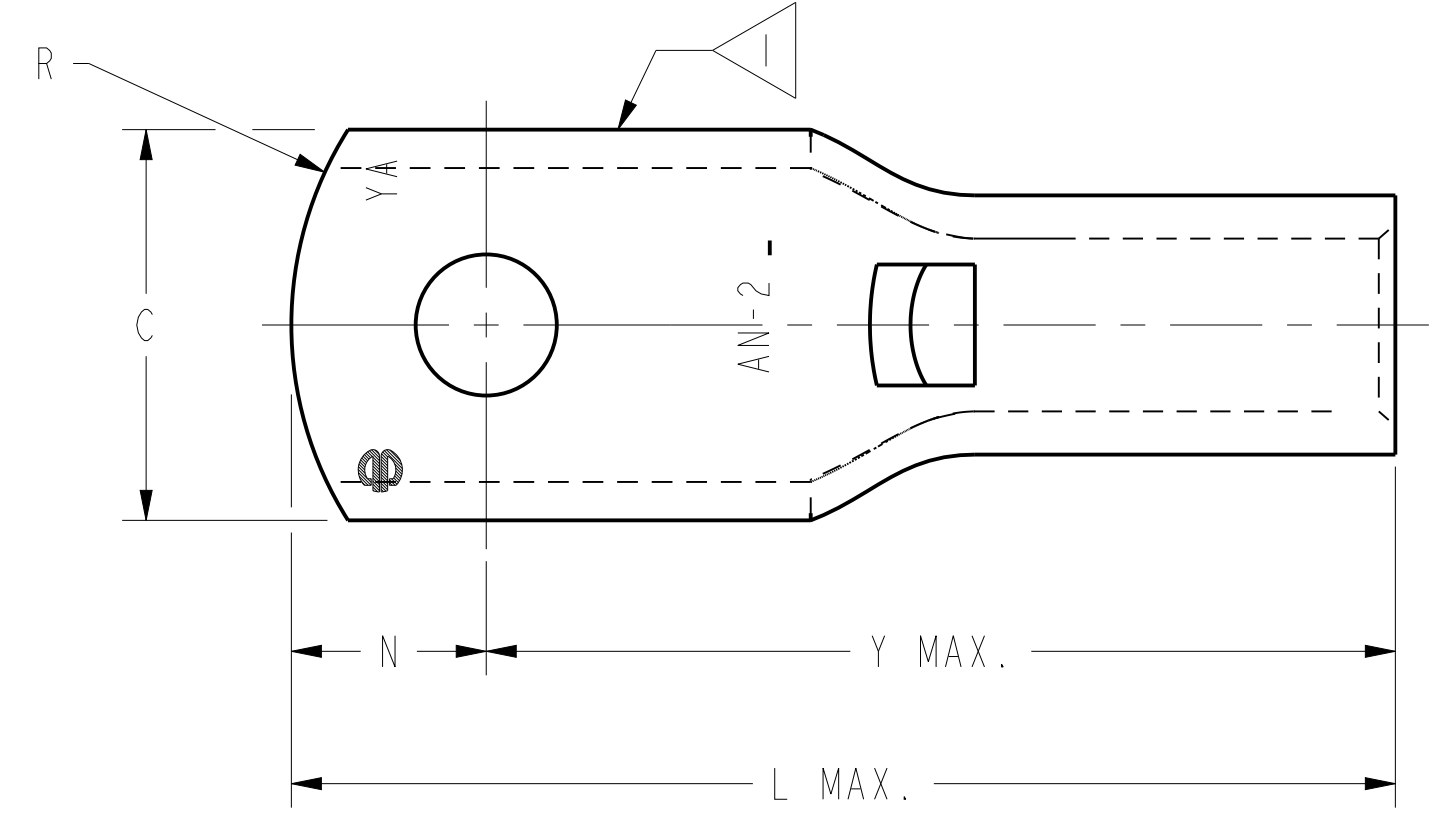

- NOTES:
1. DUE TO METHODS OF MANUFACTURING, SERRATIONS APPEAR ON TONGUE.
 2. MATERIAL: COPPER TUBING
 3. STANDARD FINISH: TIN PLATED
ALTERNATE PLATING OPTIONS: ADD SUFFIX TO DENOTE DIFFERENT PLATING REQUIREMENTS.
NK = NICKEL PLATING
W = HOT TIN DIP.
SV = MATTE SILVER PLATING
BR = BARE (UNPLATED)
LD = LEAD PLATING
 4. ALL ITEMS ARE LISTED BY UNDERWRITERS LABS PER CONTROL NUMBER 670-B, FILE NUMBER E9498, WHITE CARD.
 5. ADD "B" SUFFIX FOR BELLED BARREL. BELLED VERSIONS OF THESE HYLUGS™ DONT'T CONFORM TO THE MS20659 DASH NO.

CAT. NO. YAV6C-L10B
SUPERSEDES: SA16635

| | | | |
|----------------|---------------------|------------|-----|
| HYLUG™ | | | |
| ITEM NO: | N/A | | |
| CAT. NO: | YAVL (SEE TABLE) | | |
| DRAWN BY: | ESK | 02-02-73 | |
| CHECKER: | TB | 06-01-77 | |
| DSN APPVL: | TB | 06-01-77 | |
| MFG APPVL: | -- | -- | |
| QA APPVL: | -- | -- | |
| MKT APPVL: | -- | -- | |
| PROD FAM: | PROD./SMALL COMPRE. | DRAWING NO | REV |
| PROJECT #: | SIZE | SD034764 | C |
| DOCUMENT TYPE: | D | | |
| REL LEVEL: | | | |



SCALE: 3:1

REV: PEO200